

Product Document

Athena – 3D Face Identification



Description

Athena is an arm® based 3D face identification solution that allows users to assess ams' software capabilities and 3D sensing solution performances.

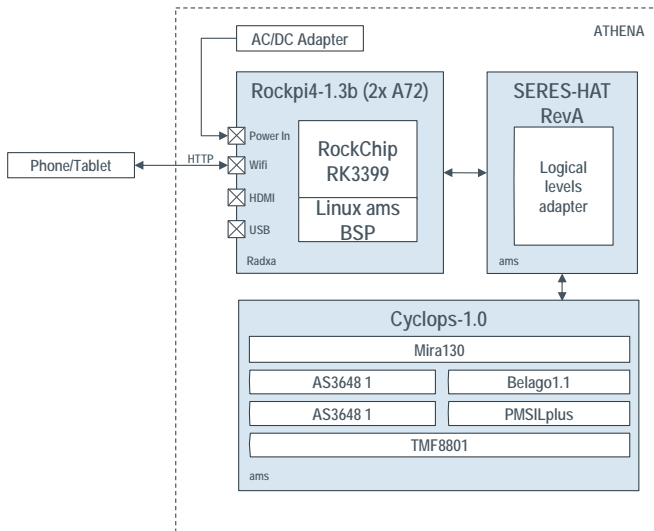

Figure 1 Athena Block Diagram

Key Features

- Fast and safe user identifications.
- Low BOM cost thanks to our structured light based 3D sensing module.
- Arm® compatible solution; can be ported on a large variety of arm® SOCs.
- Biometric software API enables quick prototyping and development of POC and prototypes.
- Self-contained, no need for yet-another-app to connect to the demonstrator.
- Web based operations for demonstration and evaluation.
- Straight forward enroll process, supporting profile enrollment with and without glasses.
- ams hardware and software components

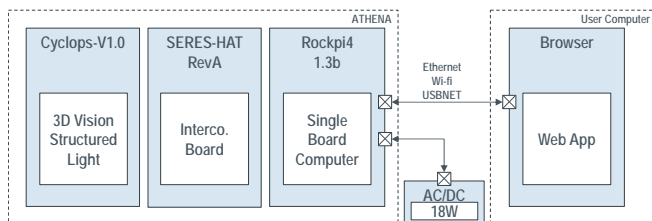

Figure 2: Block diagram of a connected system.

System Specifications

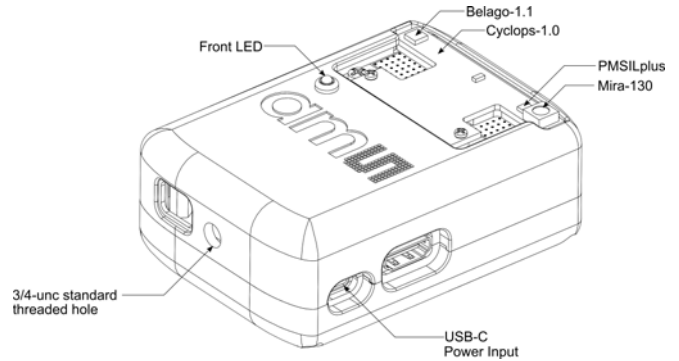

Figure 3 Athena System

Mechanical	
Length	97 mm [3 in 5/8]
Thickness	37 mm [1 in 1/2]
Width	70 mm [2 in 3/4]
Power (max.)	18 W
Power interface	USB-C
Heat dissipation	Passive cooling
Components Selection	
NIR Camera	Mira130 (1280*1080px)
Flood Illuminator	PMSILplus
Dot Illuminator	Belago1.1
1D-TOF	TMF-8801
SOC	RK3399 (4xA53 & 2xA72)
3D Sensing	
Baseline Structured Light	50mm
Structured Light dots	5K
Interfaces	
Wifi	Hotspot router for users.
USB-C	Power input.
Front LED	System status.
Use Case	
Maximum users	10 profiles
Video preview	Yes (compressed feed!)
Time to identify	380 ms (typical)
Vertical field of view	58.2°
Horizontal field of view	50.3°
Minimal Range of Operations	30cm
Maximal Range of Operations	50cm
Biometric	FAR 1:50'000 for FRR≤3%
PAD	Liveness detection, paper attacks, mask attacks
Known Limitations	Higher FRR is expected in outdoor conditions, in particular with sidelight.